

INSTRUCTIONS

INDEX

1. GENERAL
 - 1.1 NORMAL USE
 - 1.2 GUARANTEE
 - 1.3 TRANSPORT AND STORAGE
2. OPERATION
3. MARKING
4. SPECIFICATIONS
 - 4.1 MAIN FEATURES
 - 4.2 OPERATING AMBIENT CONDITIONS
 - 4.3 WIRING
5. TEST
 - 5.1 OVERSPEED DETECTION AND SAFETY CIRCUIT INTERRUPTION
 - 5.2 DEVICE RESET
6. MAINTENANCE

INSTRUCTIONS

1. GENERAL

1.1 NORMAL USE

The main function of the SEL-20 device is to detect the rotating speed of the speed governor or any rotating element of the lift and, depending on its type, interrupt the safety circuit of the lift controller. The safety circuit shall remain interrupted until the reset is executed.

The safety circuit SEL-20 is meant to detect overspeed in the following cases:

- 1.) In compliance with EN 81-20 standard, section 5.6.2.2.1.6 a) electric safety device mounted on the overspeed governor or another rotating element of the lift, meant to detect overspeed and initiate the stopping of the machine.
- 2.) In compliance with EN 81-20 standard, section 5.6.6, electric safety device meant to detect overspeed and make the car stop or reduce its speed.

1.2 GUARANTEE

LUEZAR-ECO, S.L. shall provide a guarantee against any defects in materials and workmanship during the period stipulated by current legislation.

This guarantee shall not be valid in the following cases:

- Inappropriate or undue use.
- Faulty installation.
- Superficial impacts and dents.
- Faulty electrical connections.
- Undue maintenance.

As well as an overall non-compliance with the instructions detailed in this handbook.

The integral components and parts of the SEL-20 device must not be opened, manipulated or modified. Any such action must be carried out by LUEZAR-ECO, S.L.

LUEZAR-ECO, S.L. reserves all rights to modify the content of this document without prior notice, thus cancelling the validity of its previously revised copies.

1.3 TRANSPORT AND STORAGE

SEL-20 device must be carefully packaged for shipping so as to remain protected from damages, moisture, dirt and bad weather at all times.

The device does not have a maximum storage period. But if upon its unpacking some damage is detected, such as dents or exposure to moisture, the device must be returned to the factory for its further examination, upon agreement with LUEZAR-ECO, S.L.

INSTRUCTIONS

2. OPERATION

The main function of SEL-20 electronic device is to detect the speed of the lift upon reaching which the main lift safety circuit is interrupted and the lift is ordered to stop.

SEL-20 electronic device reads at least 8 rotations of the magnets (red) embedded in the overspeed governor or another rotating element of the lift and translates them into the linear speed of the lift (see picture).

Once the safety circuit is interrupted the device has to be reset to return to the normal operation of the lift. Resetting is performed by applying a pulse of 24Vdc between 0.5 and 3 seconds. The procedure is detailed in section 5. Test of this instruction manual.

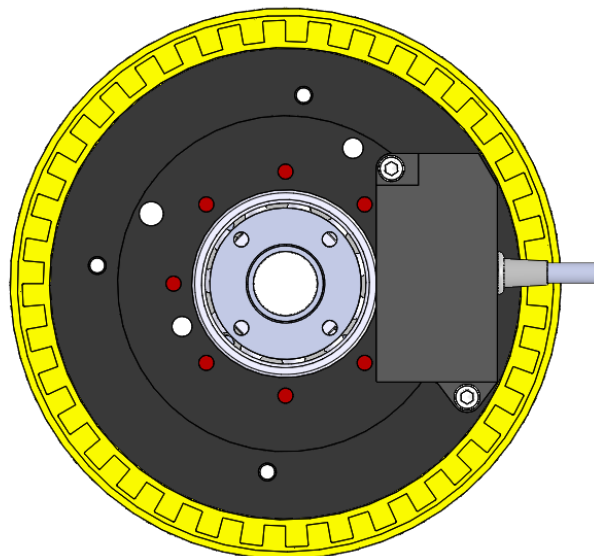

3. MARKING (CE PLATE)

Each unit bears a marking plate with the product name, its manufacturing number (F.Nr), manufacturing date (F.Date), certificate number as well as the name and address of the manufacturer.



INSTRUCTIONS

4. SPECIFICATIONS

4.1 MAIN FEATURES

Electrical specifications	
Power supply voltage	24 Vdc
Minimum supply voltage	20 Vdc
Maximum supply voltage	30 Vdc
Battery power supply	24 Vdc
Reset supply voltage	24 Vdc
Minimum reset supply voltage	18 Vdc
Maximum reset supply voltage	36 Vdc
Nominal supply current	125 mA
Reset nominal current	20 – 30 mA
Allowable voltage range safety circuit contact	5 to 250 Vdc / Vac
Maximal switching capacity safety circuit	AC 15 230 V 5A DC 13 24V 5A 0.1 Hz
Switching current range safety circuit	3 mA to 10A
Maximum response time	27 ms
Pollution Degree (EN 60664-1)	2
Maximum detection speed	3.20 m/s

To ensure the correct operation of the device it must be powered in accordance with the requirements detailed in the specifications table.

If necessary, the device can be powered by the battery following the specifications detailed in the above-mentioned table.

4.2 OPERATING AMBIENT CONDITIONS

Temperature	(-30°C) ÷ (+65°C)
Relative humidity	10 - 85 %

4.3 WIRING

SEL-20 device is fitted with 6 terminals and is supplied as shown in the following picture

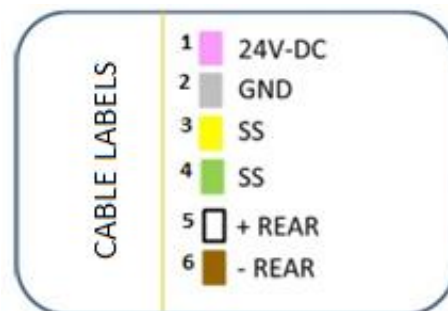
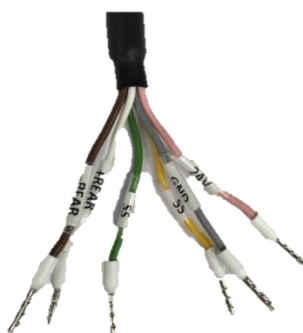

INSTRUCTIONS

Terminals of the device supplied are pin-shaped. The cable ends are marked according to the colour code described in the top right image.

Pin connectors dimensions are as follows:

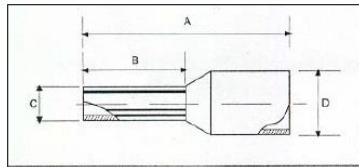
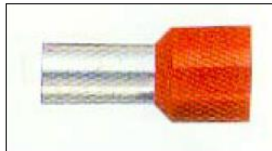

DIN 46228/4

INSULATED PIN CONECTORS	SECTION mm ²	A	B	C	D	COLOUR System "T"
TE-0.50	0.50	14.0	8.0	1.0	2.6	White

The device can be supplied with connectors upon prior agreement with the client.

The following table contains electrical data on the connections of the device.

Colour	Terminal	Description
Pink	1	Device power supply 24 Vdc (+)
Grey	2	Device power supply 0 Vdc (-)
Yellow	3	Safety circuit contact
Green	4	Safety circuit contact
White	5	Device reset power supply 24Vdc (+)
Brown	6	Device reset power supply 0 Vdc (-)

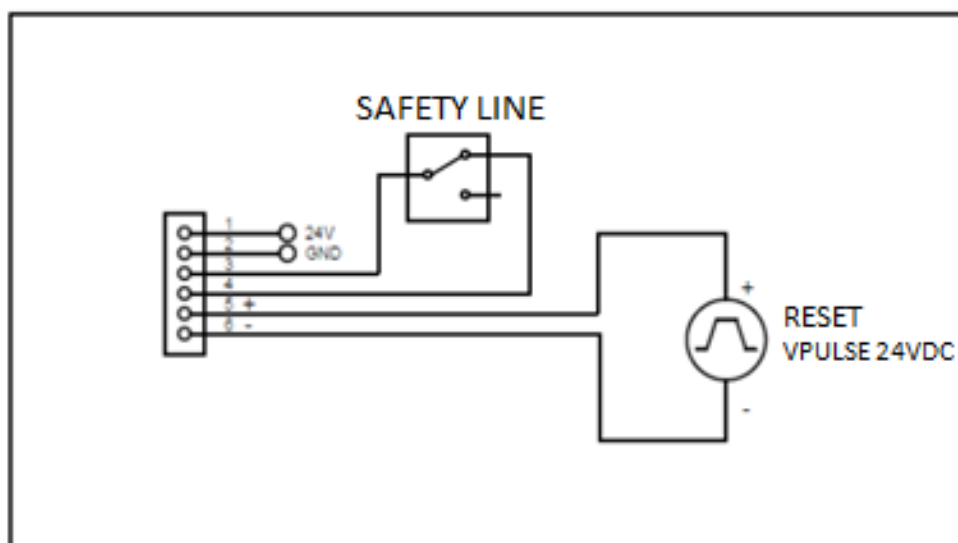

INSTRUCTIONS**5. TEST**

To verify the correct operation of SEL-20 device upon its installation, the following tests shall be performed:

5.1 OVERSPEED DETECTION AND SAFETY CIRCUIT INTERRUPTION.

To make sure that the device interrupts the safety circuit in the event of overspeed, the speed of the lift must exceed the nominal speed. Therefore, if possible, during the installation the following procedure must be carried out:

- Set the nominal speed that exceeds the original one in the following interval:
($v_{test} = 1.2 * v_{nominal}$) a ($v_{test} = 1.25 * v_{nominal}$)
- Call the lift from the floor where it can reach the speed, v_{test} , during the ride.
- Make sure that during the ride overspeed gets detected and that the safety circuit is subsequently interrupted.

5.2 DEVICE RESET

During the procedure detailed in section 5.1, the safety circuits of the device remain interrupted and the lift is therefore stopped and unable to move.

To return the system to its initial position or regular operation the device must be reset as follows:

- Apply a pulse between terminals 5 and 6, (in accordance with section 4.3 wiring of this manual) of 24Vdc between 0.5 and 3 seconds.

ATTENTION

Make sure the polarity is correct (as specified in paragraph 4.3 Wiring of this manual).

- Make sure the safety circuit contact has been closed; if this is the case, the device has been reset correctly.

IMPORTANT, while the reset pulse is active the SEL20 system doesn't detect the overspeed.

6.- MAINTENANCE

The tests detailed in the previous section shall be performed once every five years basis to ensure the correct operation of the unit in the course of its useful life.